

young®
CORPORATION

MODEL RL
CLAMSHELL BUCKETS

Quality since 1902

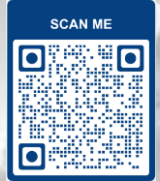

Young Corp. PO Box 3522, Seattle, WA 98124 (800) 321-9090 www.youngcorp.com

For loose materials up to 2000 lbs. per cubic yard

Models	Max. Machine Size (lbs.)	Capacity (cu yd)	Weight (lbs.)	A	B	C	D	E
RL-150DBE	135,000	1 1/2	5,150	53 1/2	103 1/2	59 1/2	70 1/4	87 3/4
RL-200DBE	135,000	2	5,470	58 1/2	109 1/4	64 1/2	70 3/4	90 3/4
RL-250DBE	135,000	2 1/2	5,770	62 1/2	114 1/4	69 1/2	71 1/4	93 1/4
RL-300DBE	135,000	3	6,060	67 1/2	118 1/4	73 1/2	71 3/4	95 1/4
RL-350DBE	135,000	3 1/2	6,700	67 1/2	123 3/4	76	79 1/4	103 1/2
RL-400DBE	135,000	4	6,990	73 1/2	127 3/4	79 1/2	79 3/4	105 1/2
RL-450DBE	135,000	4 1/2	7,220	76 1/2	130 1/2	82 1/2	80	107
RL-500DBE	135,000	5	7,440	79 1/2	133 1/2	85	80 1/4	108 1/2
RL-455DBE	135K - 200K	4 1/2	9,960	77	132 1/2	83 1/2	95 1/2	119 1/2
RL-505DBE	135K - 200K	5	10,210	80	135 1/2	86	95 3/4	121
RL-550DBE	135K - 200K	5 1/2	10,470	82	138 1/2	89	96 1/4	122 1/2
RL-600DBE	135K - 200K	6	10,720	84	141 1/4	91 1/2	96 1/2	124
RL-700DBE	135K - 200K	7	11,270	89	146	96	97 1/4	126 1/2
RL-800DBE	135K - 200K	8	11,740	93	151	100 1/2	98	129
RL-705DBE	200K - 300K	7	14,490	89 1/2	157 1/4	97	106 1/4	139 1/2
RL-805DBE	200K - 300K	8	15,090	93 1/2	162 1/4	101 1/2	106 3/4	142

- Features power rotation and replaceable bolt-on cutting edges.
- Standard hardened pins and bushings to resist rust and long wearing.
- We also offer custom sizes, weld-on edges, blunt edges, lap seals, fixed or non-rotating head, underwater seal kit and height extensions for longer reach

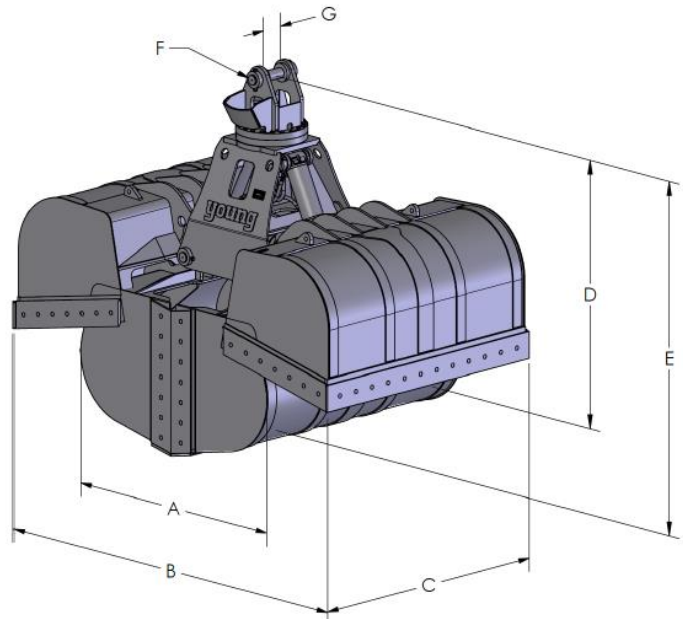

Quality since 1902